

## Jay-Be® UK

☎ +44 (0) 1924 66 66 33

✉ [service@jaybe.com](mailto:service@jaybe.com)

🕒 Mon to Thurs  
9am - 5pm (Fri 4pm)

## Jay-Be® USA

☎ (800) 779-2650

✉ [care@jaybe.com](mailto:care@jaybe.com)

🕒 Mon to Thurs  
9am - 5pm EST

Discover more at [jaybe.com](http://jaybe.com) & find us on:



## FOR YOUR SAFETY

We take your safety very seriously which is why Jay-Be® products are designed and tested to meet rigorous international Safety and Quality Standards.

However, this Folding Bed contains moving parts so please be aware of hand entrapment when operating and never allow children to play on this product.

Folding Beds are designed to lie on and weight should be evenly distributed  
Please do not jump, stand or kneel on your Folding Bed.

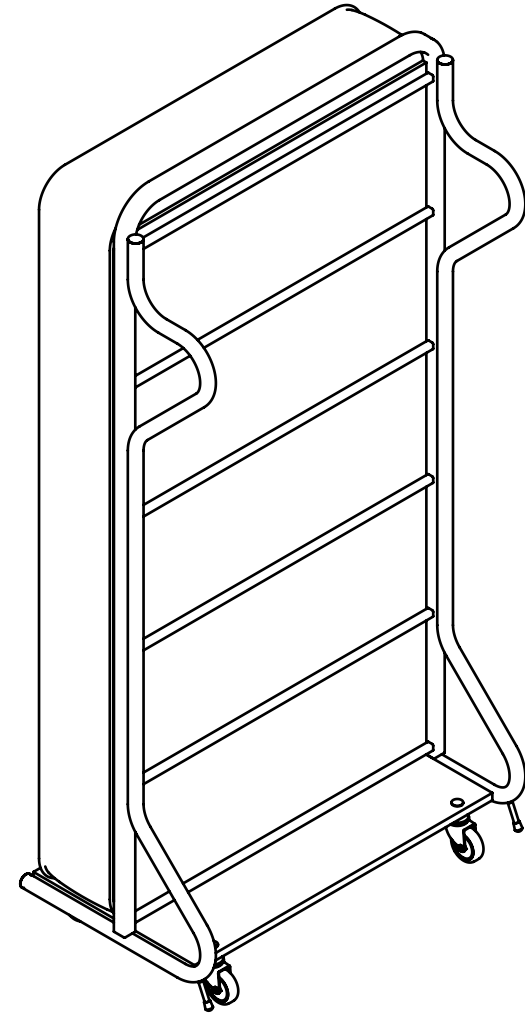

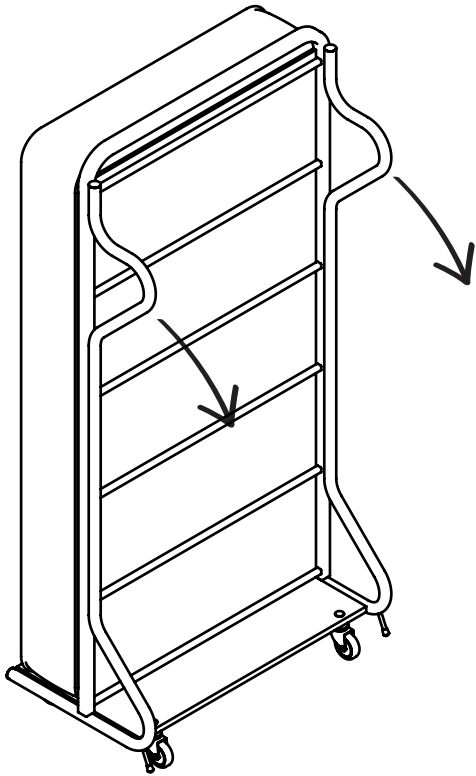

- 1** Place foot at base of the upright bed and gently pull the top of the bed frame towards you using the legs as handles.

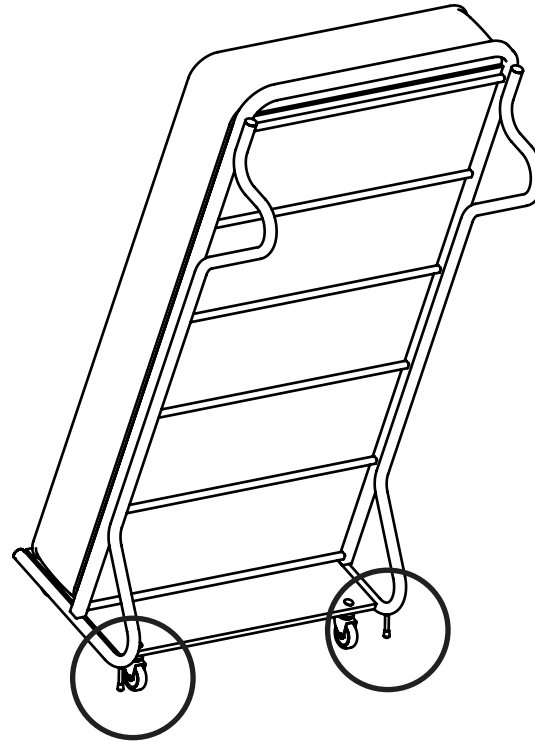

- 2** Use the pivot point to help transition the bed to the flat position.

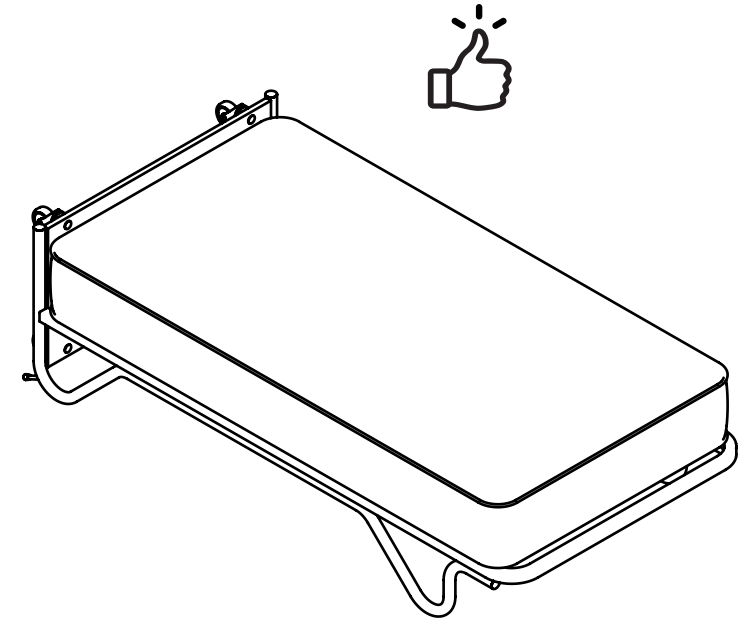

- 3** Unstrap the mattress ready for use.

